

Brake Adjustments and System Settings

With any overrun braking system the sequence of adjustment is ALWAYS:
Drum Compensator Brake rod Coupling

N.B. in the case of over centre handbrakes it is ESSENTIAL that the lever is tied down and the locking pins or stop pegs are fitted as per the manufacturer's instructions BEFORE any adjustment is carried out.

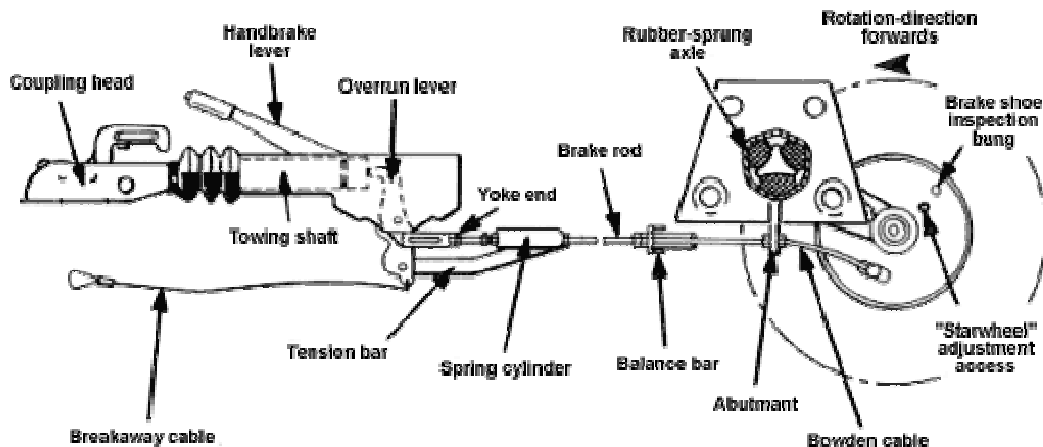

(A) Before commencing adjustment - ensure that the handbrake is fully off and that the coupling drawtube is fully extended.

(B) Linkages - slacken all nuts.

(C) Drum - adjust the linings (AL-KO through the back plate, Knott/Lockheed by the hexagonal nut on outside of back plate), so that resistance can be felt when rotating the drum forwards. Slacken adjuster until drum turns freely in the forward direction.

N.B. ALWAYS rotate the drum in the FORWARD direction, NEVER in REVERSE, otherwise the auto reverse mechanism will be activated and correct adjustment will be impossible.

(D) Repeat - on other brake units on the trailer.

(E) If an over centre handbrake is fitted - remove any locking pins or stop pegs, untie the lever. Apply the handbrake three or four times to ensure that brake shoes are centralised. Refit pins or pegs and retie lever down after last application and before proceeding to (F) below.

(F) Anchor plates - check that the nuts securing outer bowden cable are tight.

(G) Compensator - clean off any old grease and dirt. Adjust any slack out of the inner cable, but do NOT put under tension. Check that assembly runs parallel to the axle tube and that nuts and lock nuts are tight. Smear with clean grease.

(H) Brake rod - should pass through the centre of the anchor plate by at least 50mm in order to provide correct support. If rod length is excessive, additional support at the front of the trailer will be required. Adjust so that the overrun lever/brakelink just butts up against the rear end of the draw tube shaft. Tighten all lock nuts.

N.B. this applies to all over centre and gas strut handbrakes and some AL-KO spring

cylinder models. Other earlier models from Knott and Bradley, particularly those operating with rods instead of cables, may require some clearance between the draw tube and brake lever - consult the manufacturer's instructions.

(I) Spring cylinder - if fitted with a ratchet handbrake adjust the locknuts to give the required clearance. (1mm AL-KO, 3mm Knott, 1-3mm Bradley)

(J) If fitted with an over centre handbrake - remove any locking pins or stop pegs and untie the lever.

(K) Testing - fully apply the handbrake several times to test its operation. With a ratchet handbrake, the adjustment is correct if slight and equal braking resistance can be felt at each hub when turning the wheels in a forward direction with the handbrake on the second or third tooth. The same applies to gas strut models when the handbrake lever is held manually in position equivalent to first or second tooth. For over centre models apply the handbrake and turn each wheel in the reverse direction until it locks.

All brakes should lock firmly. If not, their adjustment is not tight enough and they should be readjusted as per (C) above.

(L) Remove the axle stands and jack - Check torque settings on wheel bolts.

(M) Road test - if practicable - ensuring that braking is smooth and progressive at various road speeds. (N.B. always carry out brake testing taking due account of other road users. (This is assuming that the tests cannot be carried out on private roads.)